

Technical datasheet

Jacmounts pat.
PRG 125 /705

Art. no.
1.16125.58

Application secure thanks to high level of damping. Very good stability due to high ground adhesion.

Max. load
2000 daN

Article information	
Type	PRG 125 /705
Name	Jacmounts pat.
Art. no.	1.16125.58
Color	RAL 7001 silver grey
Other colors upon request.	
Surface treatment	Painted



Technical Data		Dimensions	
Max. load [daN]	2000	Height H [mm]	24.5
Weight [kg]	0.883	Height H _{min} [mm] M16	52
Temperature range from [°C]	-15	Height H _{min} [mm] M20	63
Temperature range to [°C]	100	Height H _{min} [mm] M24	73.5
Pad equipment		Diameter D [mm]	125
Bottom pad type	705		
Pad thickness unloaded [mm]	5		
Coefficient of friction on concrete with fine mortar	0.8		
Hardness [° Shore A]	70 - 75		
Bottom pad area A ₁ [cm ²]	104		

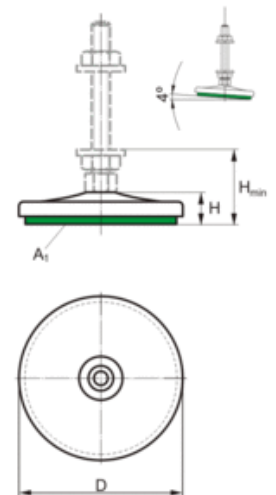

Suitable studs, special studs, leveling screws, leveling sockets		
	Special studs G2	M16, M20, M24 more

Useful remarks

The body of the element and the special levelling stud are, once installed, connected with each other, forming one single unit. The special levelling stud is exchangeable at any time by means of a patented connection.

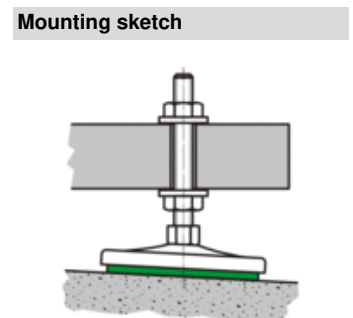

Remark extent of supply

Special studs need to be ordered separately.