

Technical datasheet

Jacmounts M16x1.5 PRSK 130-16 /725

Art. no.
1.17131-16.68

For presses, stamping and injection moulding machines, machines with high dynamic vertical force. Fast and effective movement damping.

Max. load
2250 daN

Article information	
Type	PRSK 130-16 /725
Name	Jacmounts M16x1.5
Art. no.	1.17131-16.68
Color	RAL 7001 silver grey
Other colors upon request.	
Surface treatment	painted

Type illustration



Dimensioned sketch

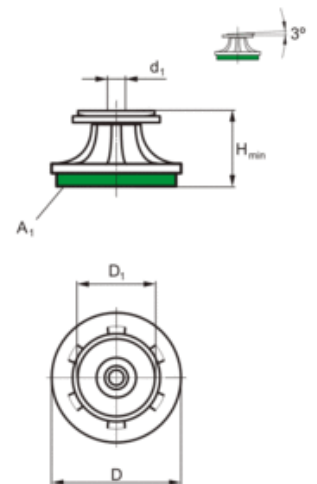

Technical Data		Dimensions	
Max. load [daN]	2250	Height H_{min} [mm]	82.5
Leveling range [mm]	20	Diameter D [mm]	129
Weight [kg]	2.617	Diameter D_1 [mm]	88
Temperature range from [°C]	-15	inner thread d_1	M16x1.5
Temperature range to [°C]	100	Pad equipment	
		Bottom pad type	725
		Pad thickness unloaded [mm]	25
		Coefficient of friction on concrete with fine mortar	0.8
		Hardness [° Shore A]	70 - 75
		Bottom pad area A_1 [cm ²]	113

Suitable studs, special studs, leveling screws, leveling sockets

	Levelling studs PRS/PRSK	M16x1.5	more
---	--------------------------	---------	----------------------

Accessories

	Spherical washers set	more
---	-----------------------	----------------------

Remark extent of supply

Levelling studs and accessories need to be ordered separately.

Mounting sketch

