

Technical datasheet

Jacmounts M20x1.5 PRSK 240-20 /910

Art. no.
1.17241-20.75

For injection moulding machines, machines with high dynamic horizontal force, Extremely high degree of horizontal stability.

Max. load
7000 daN

Article information	
Type	PRSK 240-20 /910
Name	Jacmounts M20x1.5
Art. no.	1.17241-20.75
Color	RAL 7001 silver grey
Other colors upon request.	
Surface treatment	painted

Type illustration



Dimensioned sketch

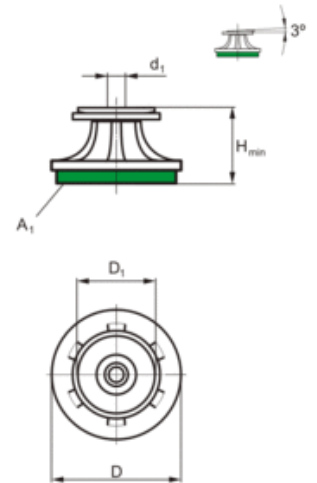

Technical Data		Dimensions	
Max. load [daN]	7000	Height H_{min} [mm]	94
Leveling range [mm]	30	Diameter D [mm]	239
Weight [kg]	10.577	Diameter D_1 [mm]	138
Temperature range from [°C]	-20	inner thread d_1	M20x1.5
Temperature range to [°C]	80		

Pad equipment

Bottom pad type	910
Pad thickness unloaded [mm]	10
Coefficient of friction on concrete with fine mortar	0.8
Hardness [° Shore A]	90 - 95
Bottom pad area A_1 [cm ²]	412

Suitable studs, special studs, leveling screws, leveling sockets

	Levelling studs PRS/PRSK	M20x1.5	more
---	--------------------------	---------	----------------------

Accessories

	Spherical washers set	more
---	-----------------------	----------------------

Remark extent of supply

Levelling studs and accessories need to be ordered separately.

Mounting sketch

