

# Technical datasheet

## Wedgmounts 2024-KSC

Art. no.  
**1.42124**

For bore, milling, long-bed machines and for machines that have to be aligned extremely precisely in all spatial axes.

Max. load  
**25000 daN**

Article information	
Type	2024-KSC
Name	Wedgmounts
Art. no.	1.42124
Color	RAL 7016 anthracite grey
Other colors upon request.	
Surface treatment	Painted

### Type illustration



### System description

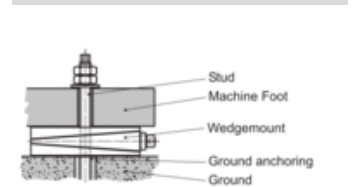

Technical Data		Dimensions	
Max. load [daN]	25000	Height H [mm]	90
Max. load + preload [daN]	48000	Length L [mm]	250
Leveling range [mm]	8	Length L <sub>1</sub> [mm]	78
Leveling range [mm]	-7	Length L <sub>2</sub> [mm]	65
Leveling distance per turn [mm]	0.18	Length L <sub>max</sub> [mm]	398
Temperature range from [°C]	-20	x [mm]	125
Temperature range to [°C]	100	y [mm]	80
Weight [kg]	20.8	Width B [mm]	160
<b>Pad equipment</b>		Inner diameter d <sub>1</sub> [mm]	27
Bottom pad area A <sub>1</sub> [cm <sup>2</sup> ]	400	Width across flats SW <sub>1</sub> [mm]	27

### Dimensioned sketch

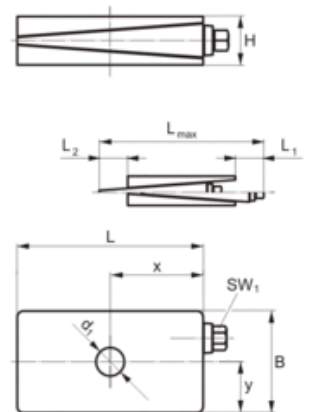

### Mounting sketch

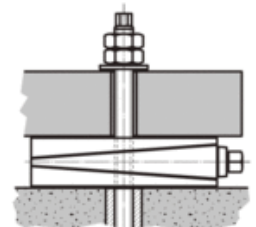

Suitable studs			
	Studs RGM	M24	<a href="#">more</a>
	Studs S	M24	<a href="#">more</a>

### Remark extent of supply

Studs need to be ordered separately.