

Technical datasheet

Wedgmounts 3-VRC-72 /NF

Art. no.
1.30003-72.61

For passive placement of sensitive devices and machine placement in multi storied buildings.
Best vibration isolation.

Max. load
1000 daN

Article information	
Type	3-VRC-72 /NF
Name	Wedgmounts
Art. no.	1.30003-72.61
Color	RAL 7016 anthracite grey
Other colors upon request.	
Surface treatment	Painted

Type illustration



System description

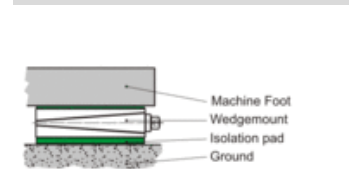

Technical Data		Dimensions	
Max. load [daN]	1000	Height H [mm]	88
Leveling range [mm]	6	Height H _{0B} in neutral position, without pads [mm]	72
Leveling range [mm]	-6	Length L [mm]	200
Leveling distance per turn [mm]	0.2	Length L ₁ [mm]	58
Temperature range from [°C]	-20	Length L ₂ [mm]	42
Temperature range to [°C]	80	Length L _{max} [mm]	301
Weight [kg]	7.55	Width B [mm]	95
Pad equipment		Width across flats SW ₁ [mm]	22
Bottom pad type	B1	Width across flats SW ₂ [mm]	12
Pad thickness unloaded [mm]	13		
Coefficient of friction on concrete with fine mortar	0.9		
Coefficient of friction tolerance +/-	0.1		
Hardness [° Shore A]	40 - 45		
Bottom pad area A ₁ [cm ²]	185		
Top pad type	903		
Pad thickness unloaded [mm]	3		
Coefficient of friction on concrete with fine mortar	0.8		
Hardness [° Shore A]	90 - 95		
Top pad area A ₂ [cm ²]	185		

Dimensioned sketch

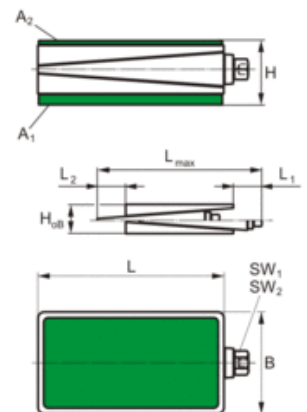

Mounting sketch

