

Technical datasheet

Insert Wedgmounds QFixx 505.6-VRKCS /915

Art. no.
1.53505-6.65

For closed machine foot design. A simple blind thread in the machine foot is necessary to create a strong and secure connection.



Max. load
6000 daN

Article information	
Type	505.6-VRKCS /915
Name	Insert Wedgmounds QFixx
Art. no.	1.53505-6.65
Color	RAL 9005 jet black

Technical Data		Dimensions	
Max. load [daN]	6000	Height H [mm]	78
Inclination [°]	3	Height H _{0B} in neutral position, without pads [mm]	63
Leveling range [mm]	3	Length L [mm]	130
Leveling range [mm]	-3	x [mm]	65
Leveling distance per turn [mm]	0.37	y [mm]	53
Temperature range from [°C]	-20	Width B [mm]	105
Temperature range to [°C]	80	Diameter D ₁ [mm]	60
Weight [kg]	3.863	Width across flats SW ₁ [mm]	14

Pad equipment	
Bottom pad type	915
Pad thickness unloaded [mm]	15
Coefficient of friction on concrete with fine mortar	0.8
Hardness [° Shore A]	90 - 95
Bottom pad area A ₁ [cm ²]	125

Useful remarks
Socket pin, dismountable.

Product contents				
Name	Type	Art. no.	Quantity	
 Insert Wedgmounds QFixx	505.6-VRKCS /915	1.53505-6.65	1	
 Threaded sleeve	M24x28.9 SW 21	7.190.1028	1	

Remark extent of supply
Supplied including plug-in bolt and thread socket for M24.

Article illustration



System description

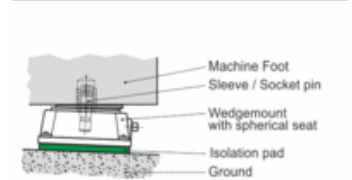

Dimensioned sketch

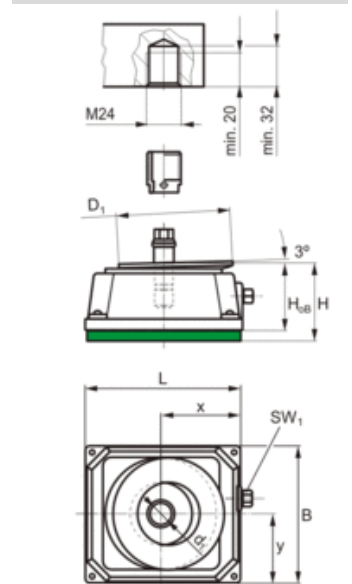

Mounting sketch

